

# OPTIMIZATION OF CYLINDER FIN GEOMETRY FOR ENHANCED HEAT DISSIPATION IN IC ENGINES

**Aarav Raghunath Kumar**

Department of Mechanical Engineering, Dayananda Sagar College of Engineering, Bengaluru-560078, India

DOI: 10.5281/zenodo.19594786

## Abstract

In internal combustion (IC) engines, fuel combustion generates extremely high-pressure and high-temperature gases, reaching temperatures between 2000°C and 2500°C. Effective thermal managements is critical to maintain optimal engine performance, as excessive heat can lead to lubricant degradation, component wear, and potential engine seizure. Conversely, overcooling reduces thermal efficiency, thereby limiting engine performance. Cylinder fins play a crucial role in balancing these requirements by dissipating unwanted heat while retaining sufficient thermal energy to enhance engine efficiency. This study investigates the influence of cylinder fin thickness and slot placement on the thermal performance of IC engine cylinders. Using numerical simulations, the study analyzes heat transfer characteristics, identifying optimal fin geometries that maintain engine temperature within the target range of 100–200°C. The results provide insight into how fin design parameters can be optimized to enhance heat dissipation without compromising thermal efficiency, contributing to improved engine reliability and performance.

**Keywords:** IC Engine, Cylinder Fins, Heat Transfer, Thermal Performance, Fin Optimization

## INTRODUCTION

In an IC engine, the combustion of the fuel mixture occurs inside the cylinder generating high- pressure and high temperature gases (around 2000-2500°C). The heat produced during combustion in the IC engine should be retained at a higher level to increase thermal efficiency. However, at the same time, to prevent thermal wear, the unwanted heat must be removed from the engine, which requires additional advanced active cooling systems; otherwise, it would result in scorching of lubricant films among several poignant devices and might cause seizures or bonding of elements. Thus, it is required to optimize these high temperatures to about 100-200°C to ensure optimum working conditions. Very high cooling rates are not looked for as they drastically affect the engine's performance by reducing its thermal efficiency. So, it is necessary to design the cooling system to prevent cooling during engine warm-up. Consequently, the cooling systems help the engine to perform effectively by maintaining its maximum working temperature, which helps to produce more heat energy as well.

Unwanted heat transferred to the engine parts must be removed rapidly, to avoid seizure of the engine due to scorching (thermal wear). Thus, air-cooled engines are used in most light vehicles as they are more compact and lighter in weight to achieve the engine's desired working conditions (Mokheimer, 2003; Hoang et al., 2019; Patel et al., 2019). Studies have illustrated that “the rate at which heat energy transfer takes place is dependent upon conduction and convection modes along its directions from surface temperature ' $T_s$ ' to surrounding temperature ' $T_\infty$ ' ”; it is presumed as,

$$\text{Heat Transfer Rate} = hA (T_s - T_\infty) \quad (1)$$

Where, 'h' is the coefficient of convective heat energy transfer, and 'A' is the area of heat flow.

From Equation 1, it has been observed that the rate of heat energy transfer could be enhanced by increasing the value of „h“ or „A“. But then, an increase in 'h' is not practically feasible, as it requires the installation of additional pumps/fans or requires swapping of the existing ones with a larger one. Thus, the surface area is considerably increased by developing individual protrusions on the exterior of the components called „fins“ to enhance heat transfer rate by conduction and convection. Hence the shape of the fins should be optimized to maximize the energy transfer rate (Aziz and Fang, 2010; Sagar et al., 2017).

Fabrication materials, fin cross-sectional area, and the number of fins used -mainly influence the engine's working effectiveness. Fins are encountered into the engine cylinder outlines because of its easy maintenance, inexpensive technology, and also it ducks some of the disputes like decrease in the strength of the piston, piston rings, and as well reduces the unwanted expansion of cylinder caused by high temperatures. Yet, if fins are more elongated, there are chances of bending, affecting their overall performance. Some of the areas of applications of fins are HVAC systems, power stations, etc.

Chaitanya et al. (2014) modelled a cylinder fin body and conducted transient thermal analysis using ANSYS. They compared Aluminum alloy 6061 with Aluminum Alloy A204 by considering the various parameters such as fin cross section, thickness and material attributes. Srinivasa et al. (2016) investigated the thermal analysis of aluminum alloy 6063 and aluminum alloy 7068 along with the universal aluminum alloy 204 by varying thickness of fins. They showcased that aluminum alloy 6063 with 2.5 mm circular fin gave better effectiveness than the other geometries. Ravindra and Prashant (2018) performed CFD analysis on heat energy transfer through fins with different types of notches cut on them and concluded that the fins with a rectangular notch had a higher thermal energy transfer rate. Sujana et al. (2019) performed thermal analysis on fins and obtained the percentage errors between the actual and the theoretical steady-state thermal analysis values. Arvind et al. (2016) examined the superlative material for improving the rate of heat transfer through fins by performing thermal analysis on various alloy made cylinders, by considering their working conditions, strength and weight of the material.

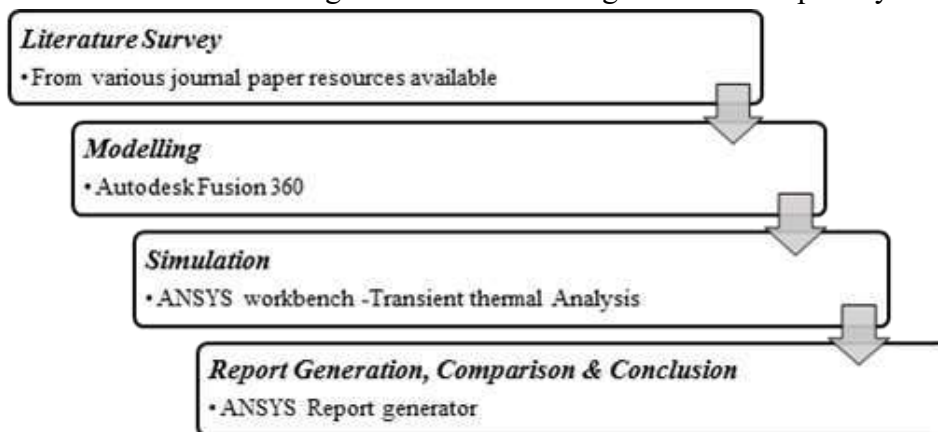
Rajvinder et al. (2016) illustrate the heat energy transfer in two different materials, such as Cast Iron and Aluminum alloy 6061. From the results obtained, they found a high heat flow rate in Aluminum alloy 6061 than those of other materials. The literature survey unveiled that research works associated with fins are limited and there were no studies based on varying fin parameters, introducing slots in fins and its variation in slot numbers, locations etc. Hence in this work, an attempt has been made to analyze the impact of the introduction of slots and varying fin thickness on the IC engine cylinder by performing transient thermal analysis. A plot of temperature and total heat flux distribution on different engine cylinder fins (varied in fin thickness) is obtained and slots are introduced to improve the heat transfer rate, reducing the material usage and cost as well. Finally, the most optimal fin model for effective heat dissipation is recommended upon inference.

### MATERIALS AND METHODS

Initially, a literature survey was conducted from various journal resources, followed by 3D modelling of the different fin geometries using AUTODESK FUSION 360 software. The geometries included rectangular and circular fins. The next stage of the simulation was done in ANSYS WORKBENCH 2020 ACADEMIC software, wherein the transient thermal analysis was carried out on the modelled fins. The material used was Aluminum alloy 6061. The data are contained in the literature surveys; many studies were subjected to steady-state Heat Transfer analysis and plot corresponding temperature distribution. However, the method followed here was to conduct transient thermal analysis and thereby to obtain their temperature and total heat-flux dispersal. Another important aspect of this study was introducing slots and examining their effect on temperature distribution, thus recommending the most optimal engine fin model for heat dissipation. The methodology adopted to complete the fin analysis is depicted in Figure 1.

#### Modelling of different engine cylinder fins

Rectangular and circular fin profiles bearing 2- and 3-mm thick fins were modelled. The number of fins for each model is 5. The distance between the two top surfaces of the fins is maintained at 13 mm. The engine cylinder's length is 75 mm, and the outer and inner bore diameters are 110 and 70 mm, respectively. Further, (8 × 10 mm) slots were introduced at the centre and the corners, as shown in Table 1. Autodesk Fusion 360 software was used to accomplish this work. The detailed fin parameters are shown in Table 1. The detailed 3D CAD model and its cross-sectional views of rectangular and circular fin geometries are portrayed in Figures 2, 3, 4, and 5.



**Figure 1.** Flow chart of methodology adopted.

**Table 1.** Fin parameters.

Fin parameters	Fin models: rectangular and circular (in mm)
Fin Thickness	2 and 3

## Research Article

Distance Between Fins	10
Length of Cylinder	75
Outer Bore Diameter	110
Inner Bore Diameter	70
Number of Fins	5
Slot Dimensions	8 × 10
Slot Location	Centre and Corner

### Analysis of Modelled Fins

Here, pre- and post-processing of modelled fins are discussed.

#### Pre-processing

Ansys workbench was used as a modelling tool for different fin geometries. The fundamental fin model was done in Autodesk fusion 360, and further, exported to Ansys workbench to carry out meshing and perform analysis. Triangular mesh was generated to give good results due to its high mesh quality. The meshing of different types of fins is reported in Figures 6, 7, 8 and 9. Transient thermal analysis was carried out, which determines temperatures and other thermal quantities that vary over time—a plot of temperature distribution results in identifying thermal stresses that can cause failure. The Loads and Boundary conditions used to analyze the fins are:

Maximum and Minimum Temperatures are 1500 and 140°C. Ambient temperature is assumed to be 22°C, Convection coefficient is 0.000083 W/m<sup>2</sup>K. The material used for the present analysis is aluminum alloy 6061. The material properties of aluminum alloy are depicted in Table 2.

#### Post processing

All the modelled fin geometries were imported into ANSYS workbench tool, and different boundary phenomena were employed to carry out virtual simulations to plot the temperature distribution and total heat flux. The post-processing results are established and reported in Figures 10-25.

### RESULTS AND DISCUSSION

Figures 26-29 illustrate the temperature and total heat flux distribution of various fin profiles along with variations in thickness and slot considerations. It is seen from the figures; the slotted fin geometries are showing a higher temperature and heat flux distribution compared to fin geometries without slots.

Commonly used materials for fin geometries such as cast iron etc. have been subjected to thermal analysis over time; however, in this present study, transient thermal analysis was performed for fin models developed from Aluminum alloy 6061. This material change was done by considering thermal conductivity and also the overall

weight of the fin. Aluminum is light in weight and has higher thermal conductivity, so using Aluminum alloy 6061 was considered as a suitable material. It is also inferred that on increasing the fin's thickness, the heat transfer rate is also increased. Further slots in the fin body reduce the fin weight; thereby, resulting in a decrease in the total weight of the engine and an increase in the fin efficiency by enhancing the rate of heat energy transfer (Figures 26-29). The percentage reduction in temperature upon the introduction of slots in each different fin model of varying thickness is given in Table 3.

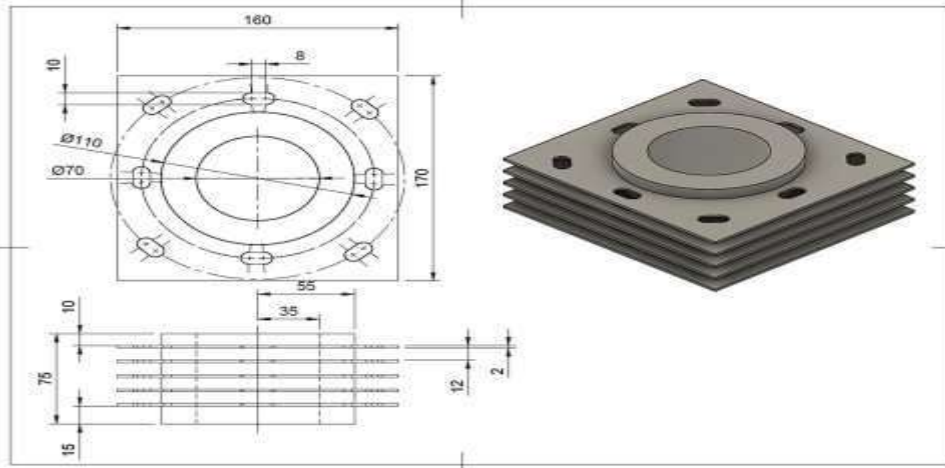
% Reduction is given by  $[(\text{New Value} - \text{Original Value}) / \text{Original Value}] * 100$

From Table 3, it is observed that Slotted Circular fin of 3mm fin thickness is having the highest percentage of temperature reduction which is 25.12% when compared to the other fin models. This indicates an increase in the heat dissipation rate.

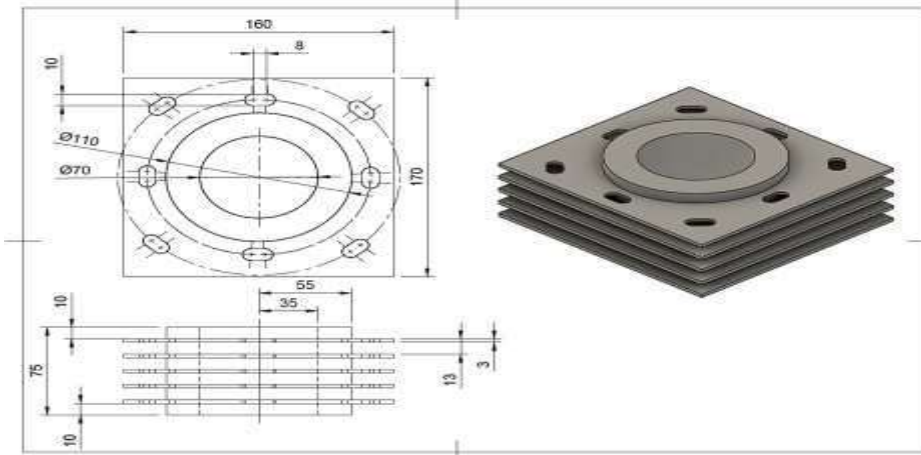
Commonly used materials for fin geometries such as cast iron etc. have been subjected to thermal analysis over time; however, in this present study, transient thermal analysis was performed for fin models developed from Aluminium alloy 6061. This material change was done by considering thermal conductivity and also the overall weight of the fin. Aluminium is light in weight and has higher thermal conductivity, so using Aluminium alloy 6061 is considered as a suitable material. It is also inferred that on increasing the fin's thickness, the heat transfer rate is also increased. Further, slots in the fin body reduce the fin weight; thereby, resulting in a decrease in the total weight of the engine and an increase in the fin efficiency by enhancing the rate of heat energy transfer (Figures 26-29).

The unwanted heat retained by the engine is reduced by slotting as it causes a temperature descent. Further, on slotting and as the fin thickness enhances an improved convective mode of heat transfer is observed.

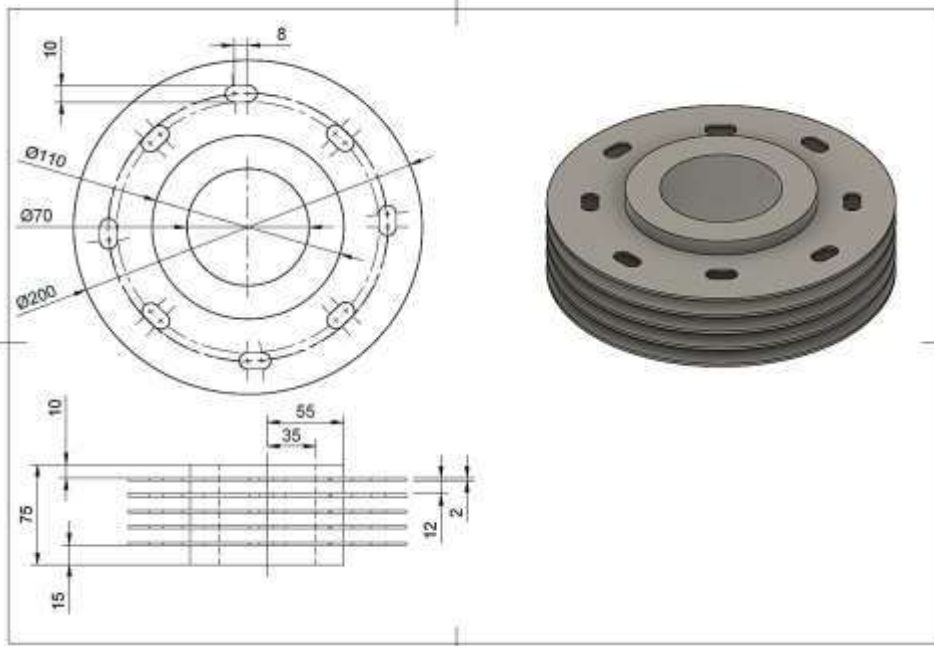
Thus, the amount of heat dissipated to the surrounding has also improved. On average, there was a considerable reduction in the temperature of the engine parts (Rajvinder et al., 2016; Maan et al., 2018; Awasarmol and Pise, 2017). The results produced by the analysis software are in the form of coloured contours of required parameters.



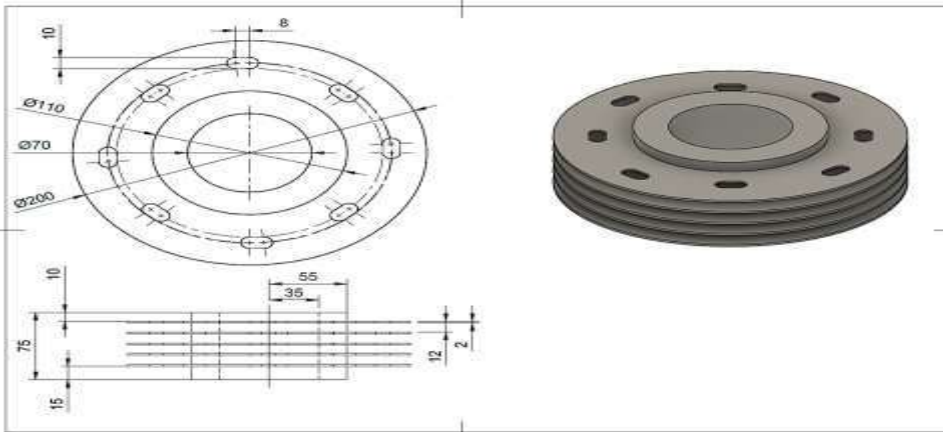
**Figure 2.** Rectangular fin model of 2 mm thickness with slots.

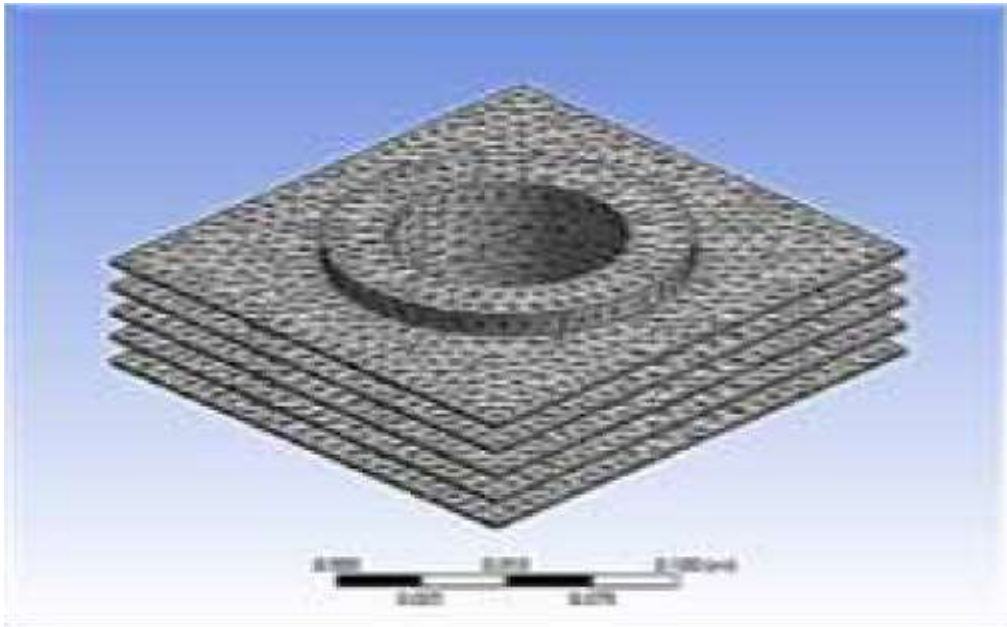


**Figure 3.** Rectangular fin model of 3 mm thickness with slots.

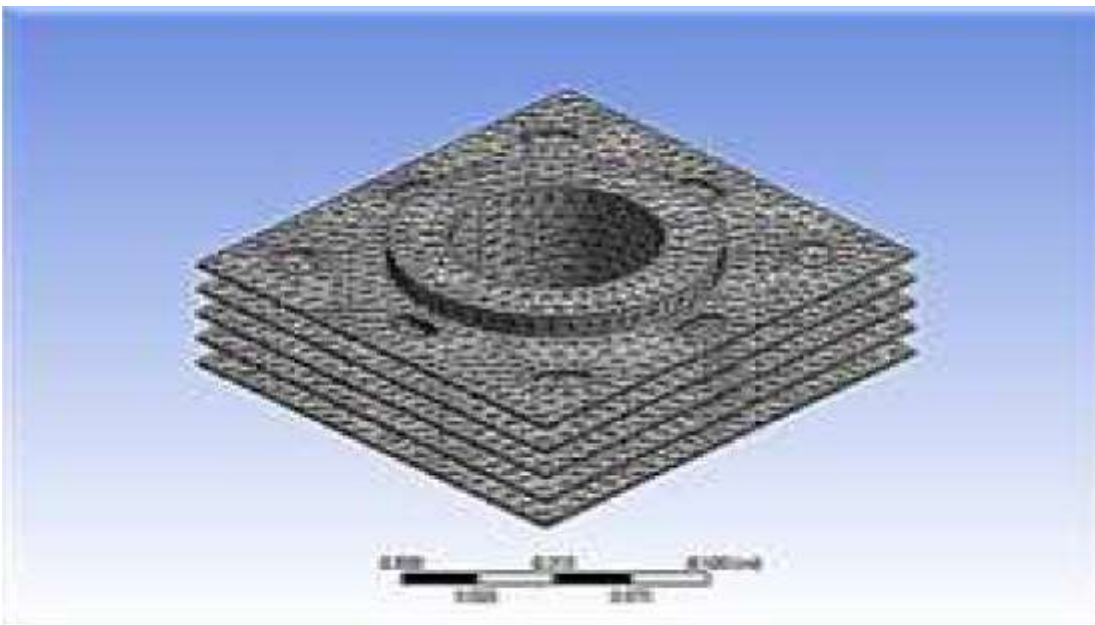


**Figure 4.** Circular fin model of 2 mm thickness with slots.

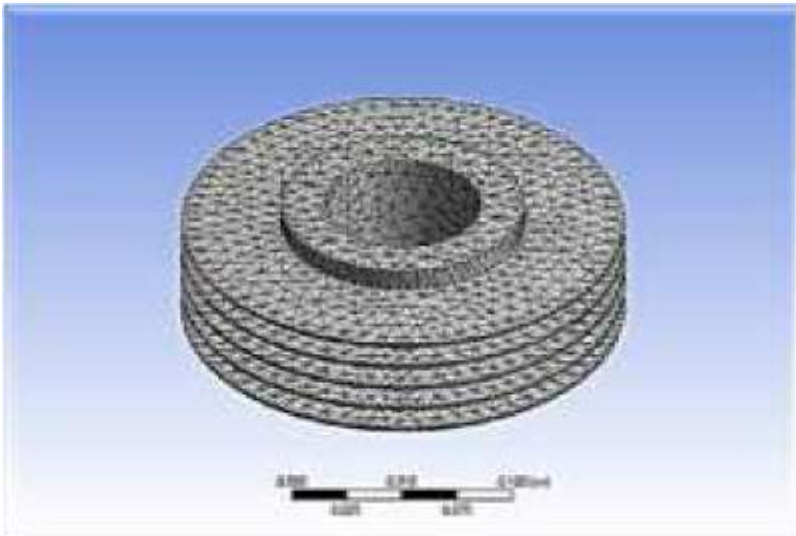




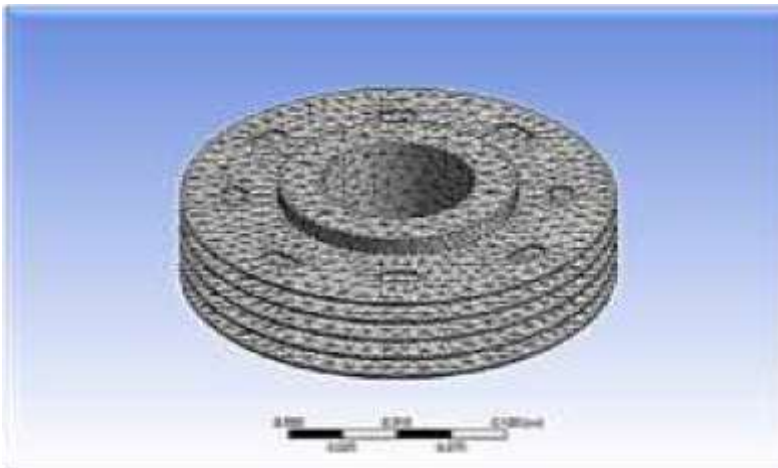
**Figure 6.** Mesh model of rectangular fin.



**Figure 7.** Mesh model of rectangular fin with slots.



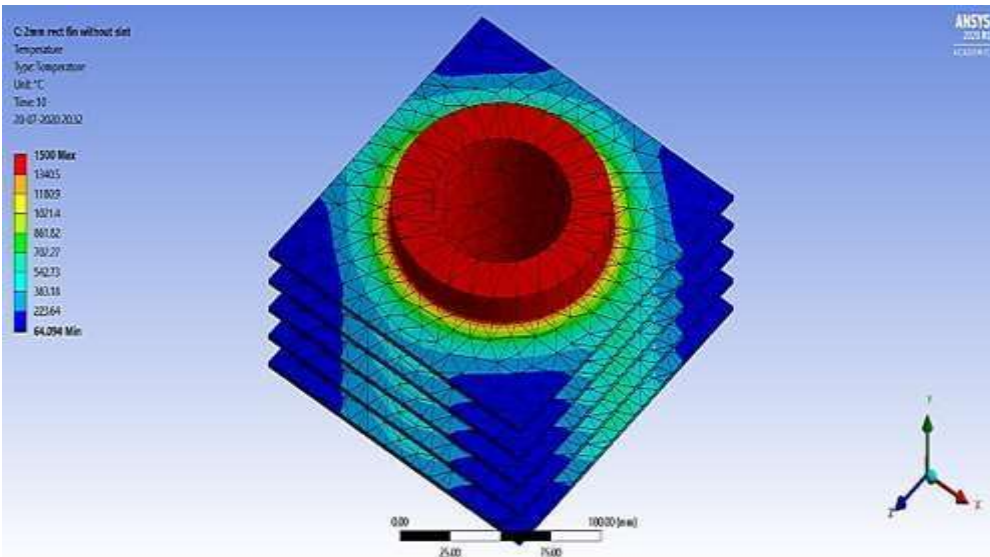
**Figure 8.** Mesh model of circular fin.



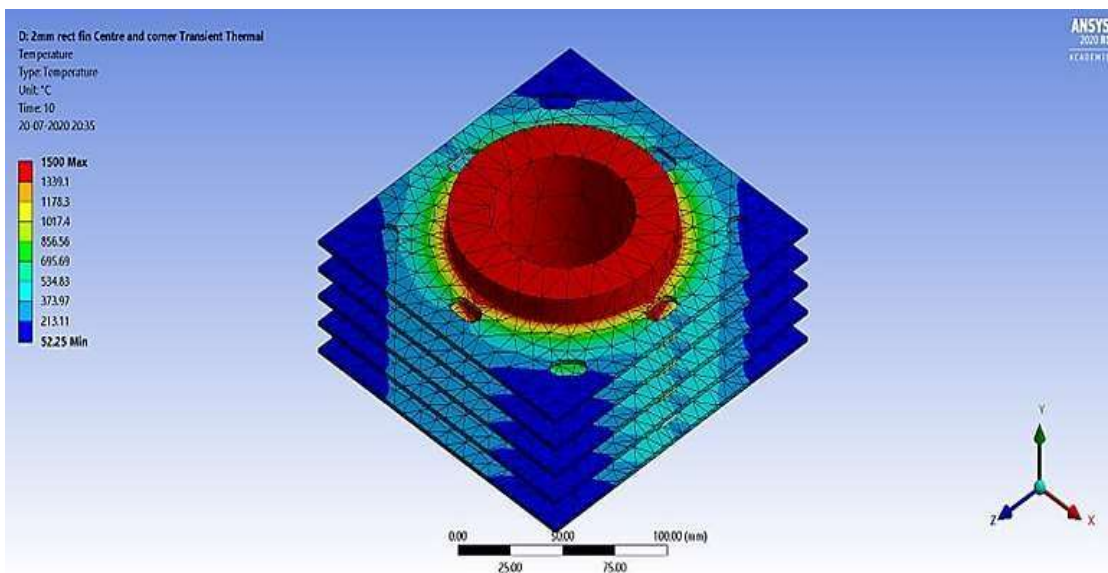
**Figure 9.** Mesh model of circular fin with slot.

**Table 2.** Material Properties of Alumunium alloy.

<b>Properties</b>	<b>Values</b>
Poisson's ratio	0.33
Elastic Modulus	69000 N/mm <sup>2</sup>
Thermal Conductivity	170 W/mK
Specific Heat	1300 J/kg K
Thermal Expansion Coefficient	2.4×10 <sup>-5</sup> /K
Density	2700Kg/m <sup>3</sup>

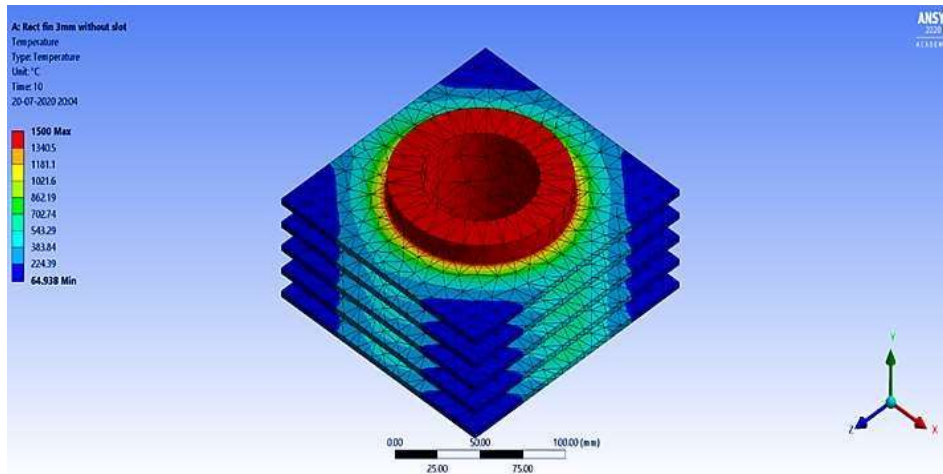


**Figure 10.** Temperature distribution in rectangular fin 2 mm thickness without slot.

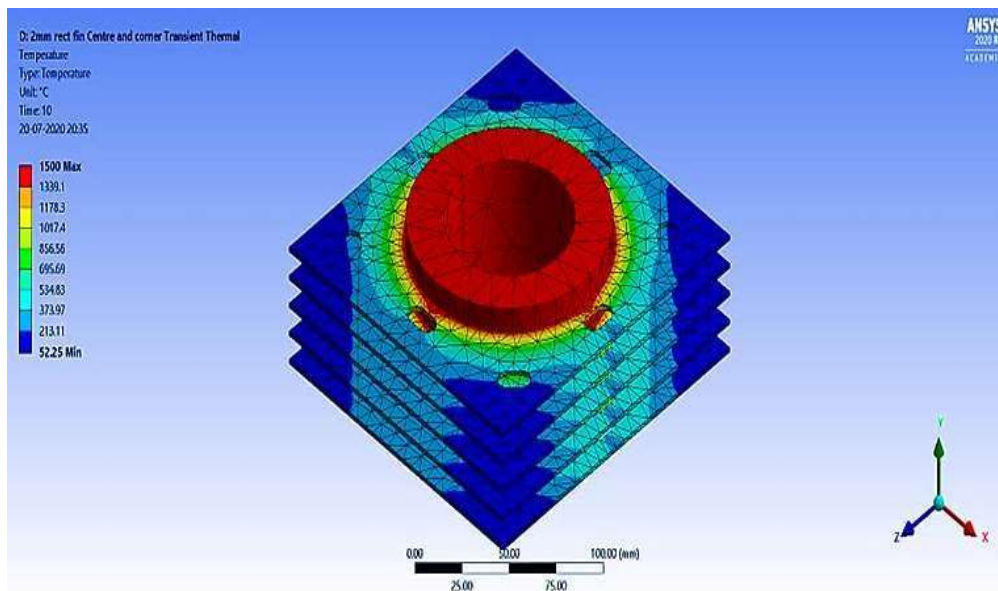


**Figure 11.** Temperature distribution in rectangular fin 2 mm thickness with slot.

The contours are such that they give an idea about the value of the parameter ranges, which are indicated in the legend. Accordingly, the circular fins with slots having a fin thickness of 3mm is observed to be the more efficient fin when compared to the rectangular fin counterpart.



**Figure 12.** Temperature distribution in rectangular fin 3 mm thickness without slot.



**Figure 13.** Temperature distribution in rectangular fin 3 mm thickness with slot.

## Conclusion

From the above results and discussion, the following are the conclusions arrived at:

- (i) Effectiveness of the fin denotes the ratio of the actual heat transfer that takes place from the body having fins to the heat that would be dissipated from the same body without fins. Slotting helps in increasing the effectiveness of the fins. Therefore, the heat transfer rate also increases considerably.

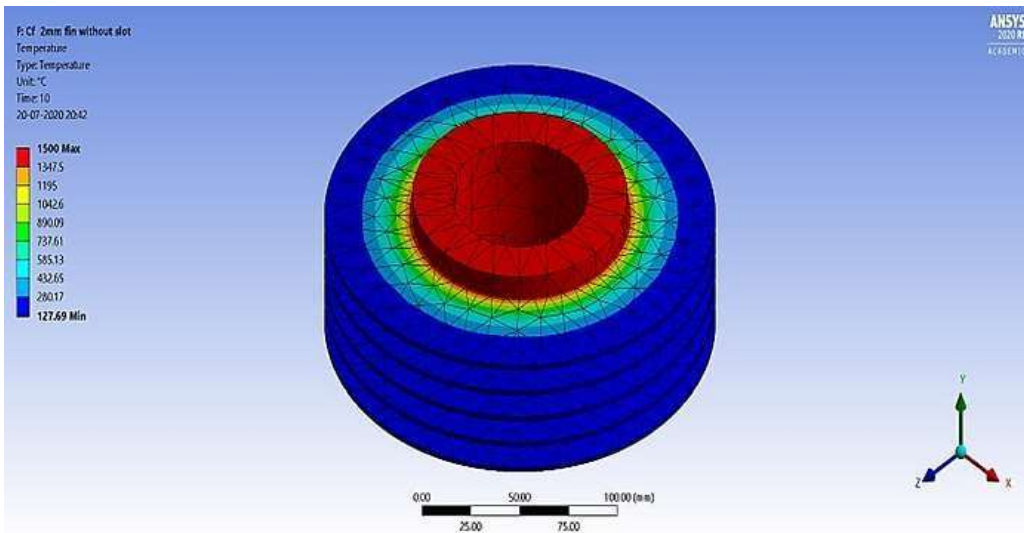
(ii) There is also a reduction in the usage of materials due to slotting, which leads to lower manufacturing costs and the engine fin component's weight. Hence, we can achieve an optimum heat transfer rate with less material

usage.

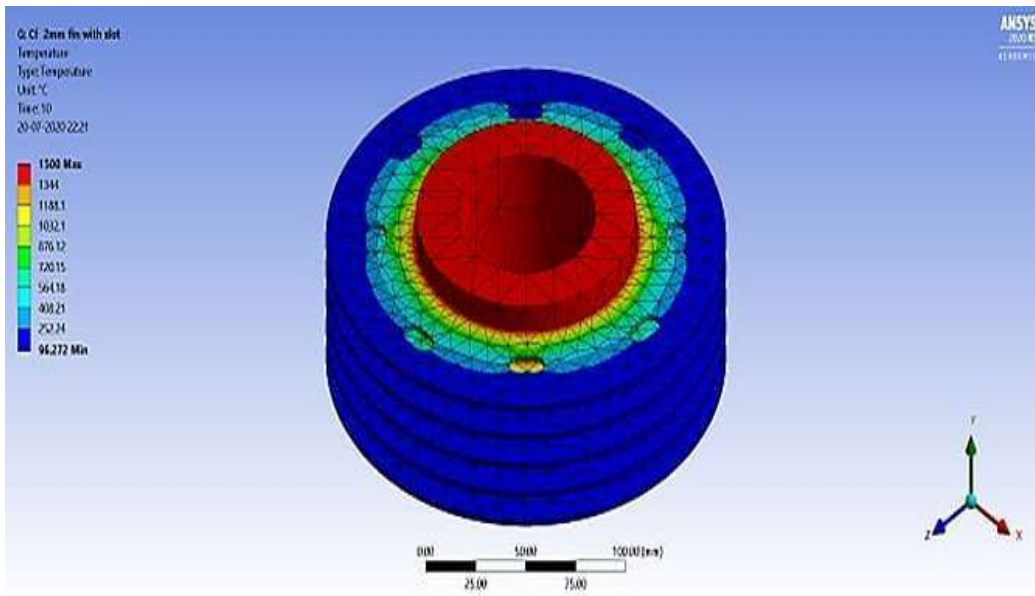
(i) The observations from the present work are fins with slots show a higher temperature distribution than those fins without slots due to an increase in the convective heat transfer rate, further increasing the overall heat transfer rate. This increase in fin thickness from 2mm to 3mm is also accompanied by an increase in heat transfer rate.

(ii) Upon comparison between the two geometries, it is seen that the slotted circular fin geometry having higher fin thickness (3 mm in this case) is the preferred fin geometry.

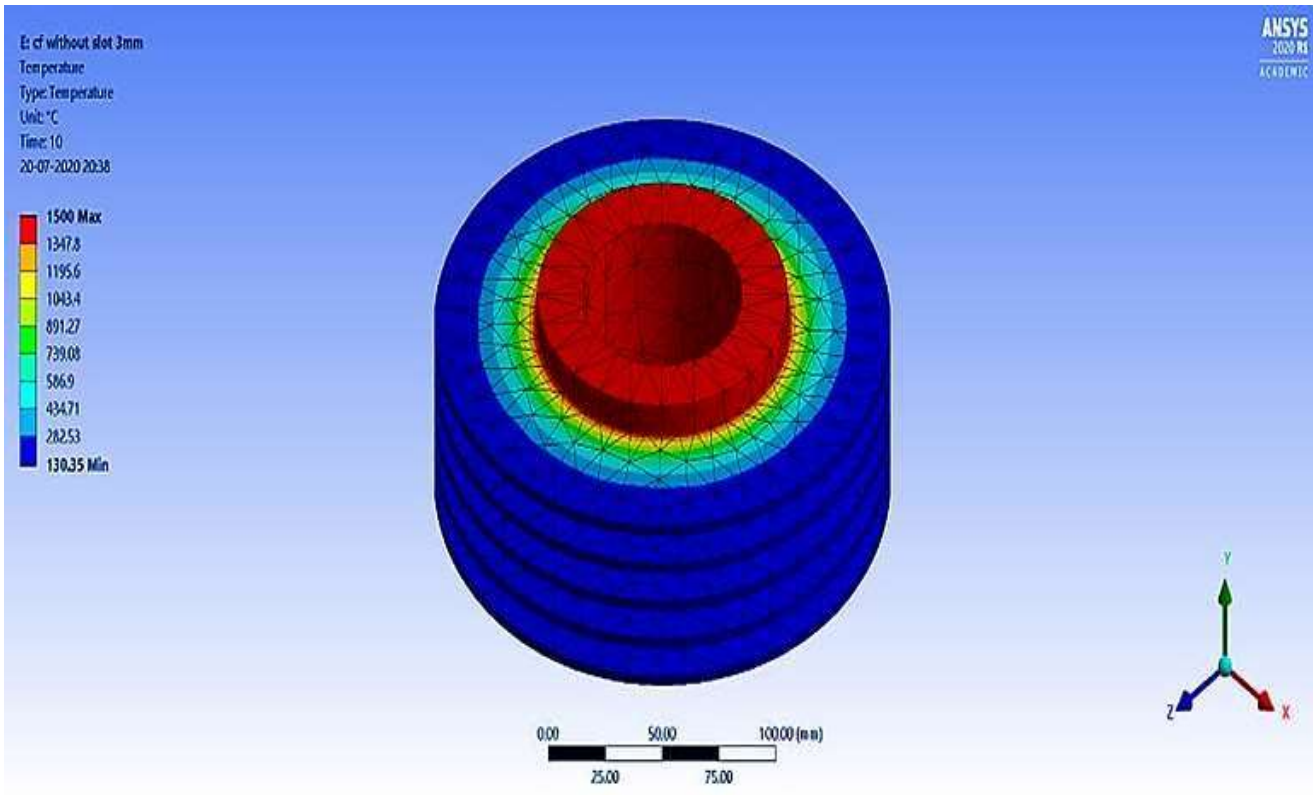
From this work, the use of slots for overall heat transfer enhancement can be justified. Consequently, the introduction of multiple slots on the fin profile enhances the overall heat transfer rate and a considerable amount of savings in the mass of the material used, thereby reducing manufacturing costs.



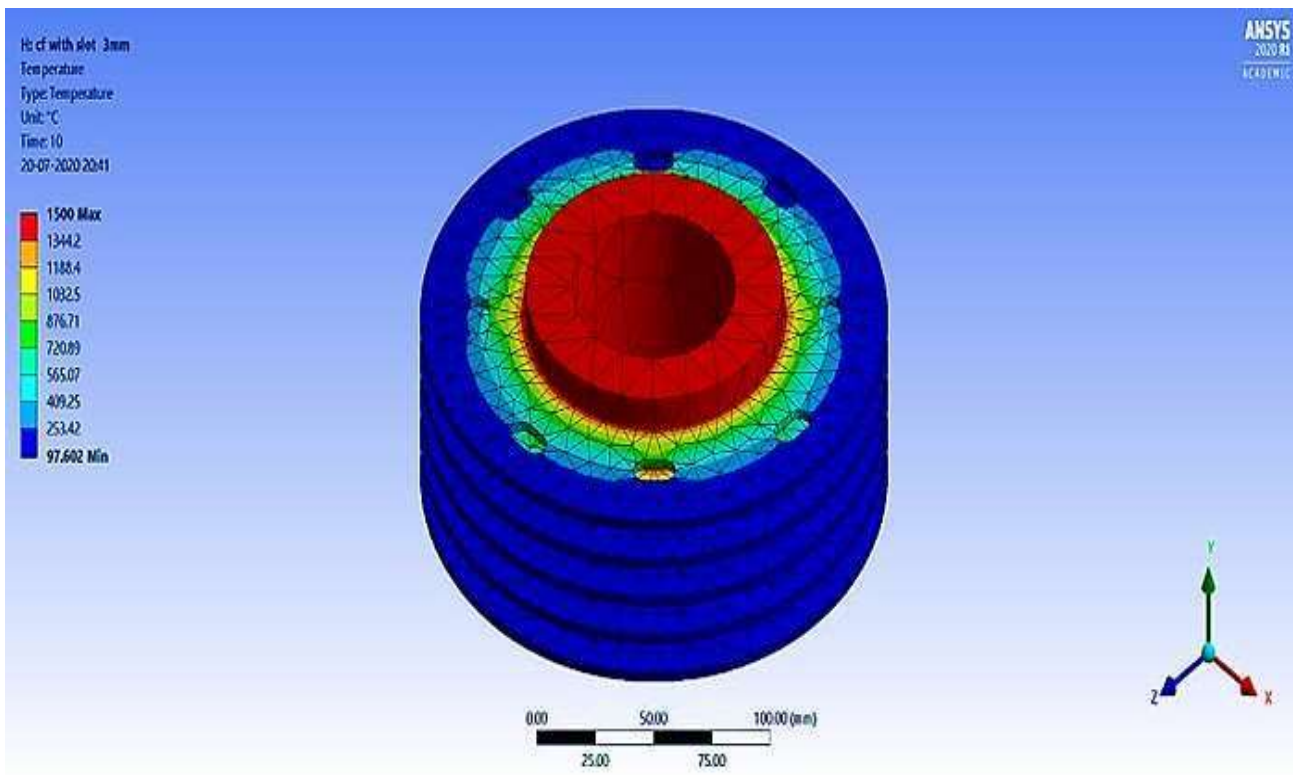
**Figure 14.** Temperature distribution in Circular fin 2 mm thickness without slot.



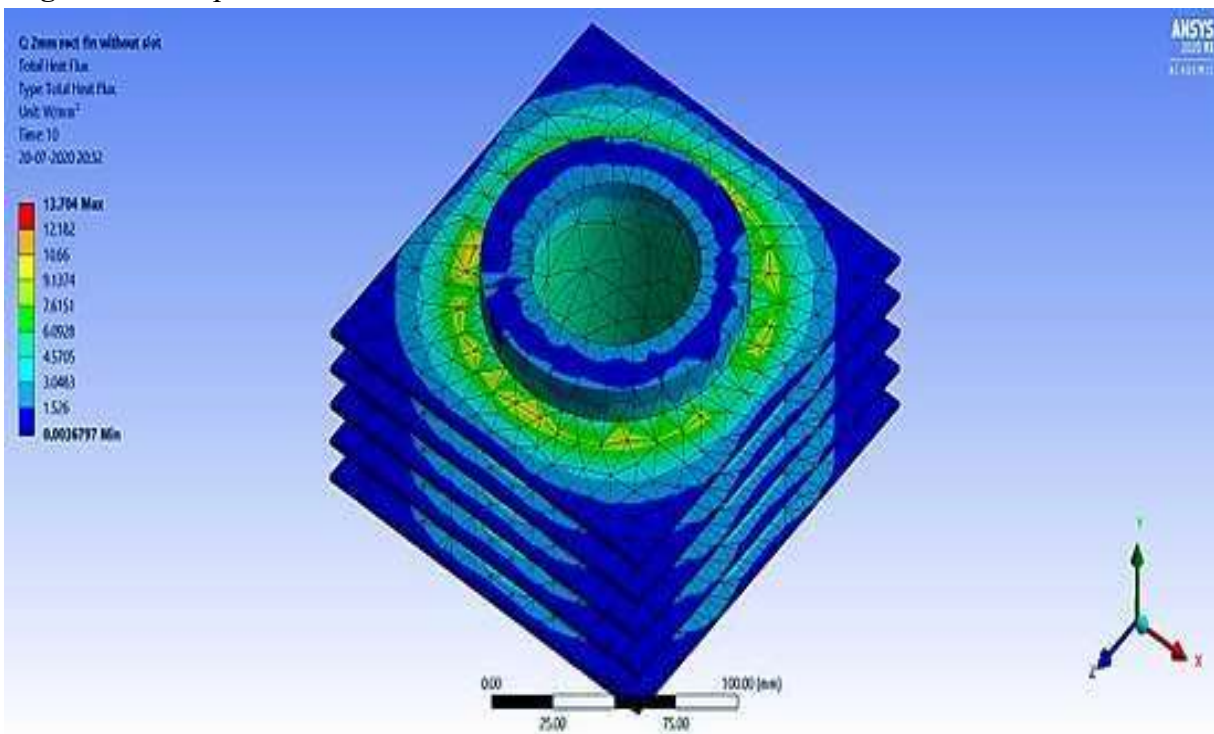
**Figure 15.** Temperature distribution in Circular fin 2 mm thickness with slot.



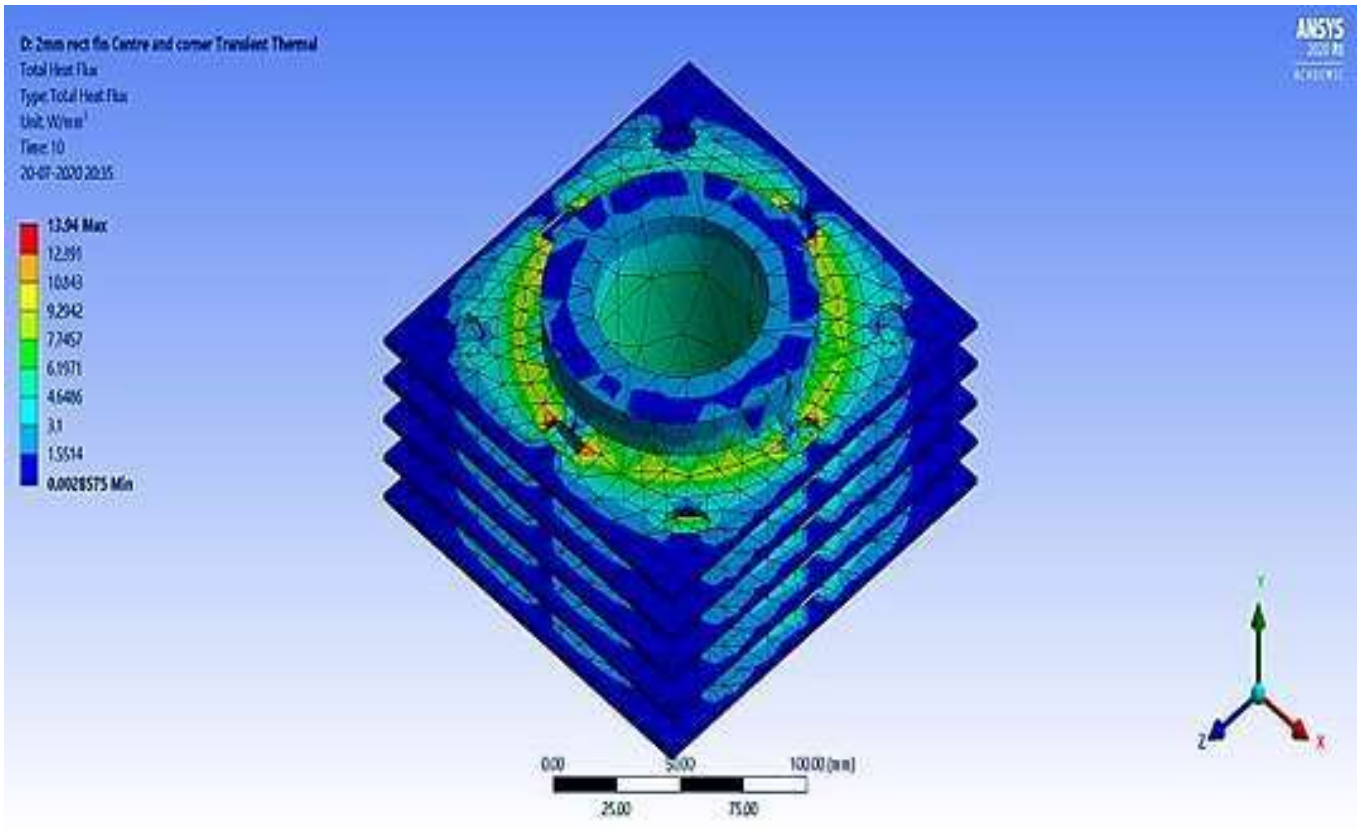
**Figure 16.** Temperature distribution in Circular fin 3 mm thickness without slot.



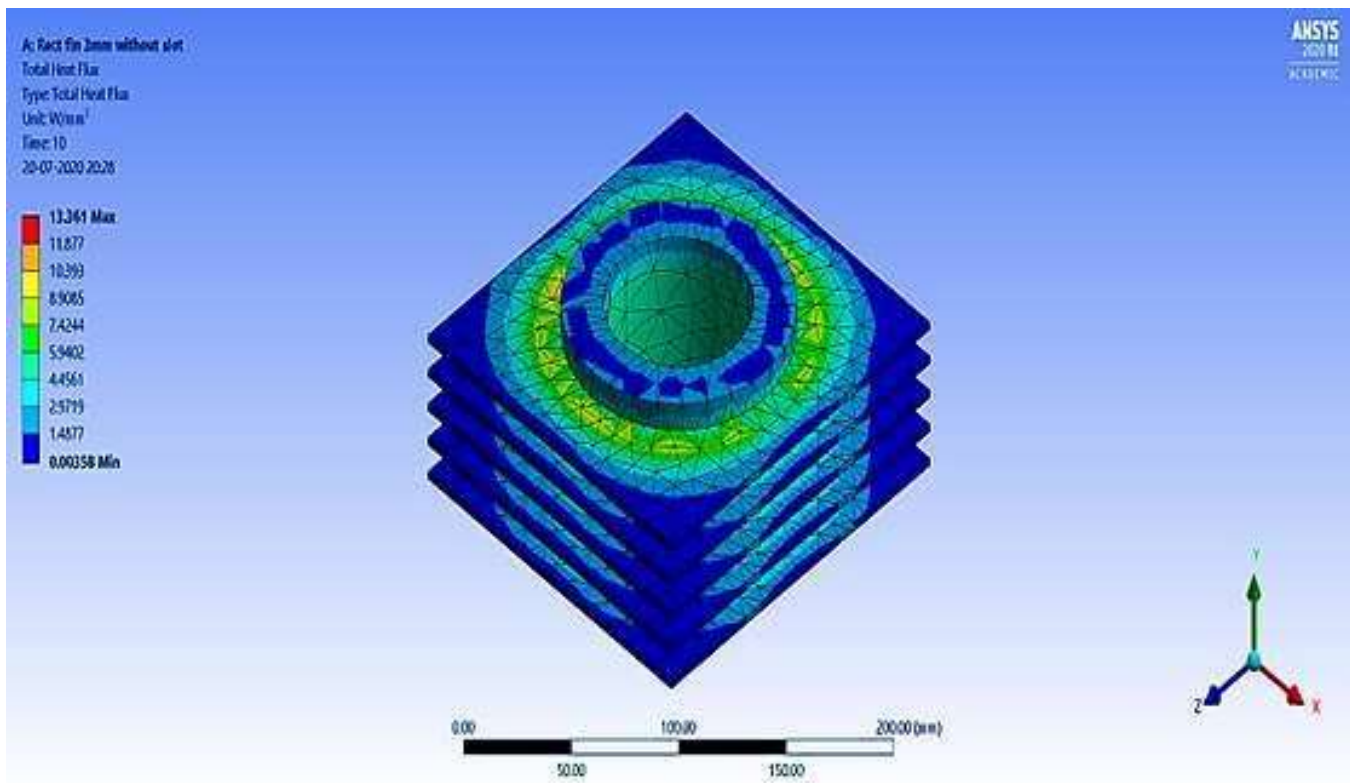
**Figure 17.** Temperature distribution in Circular fin 3 mm thickness with slot.



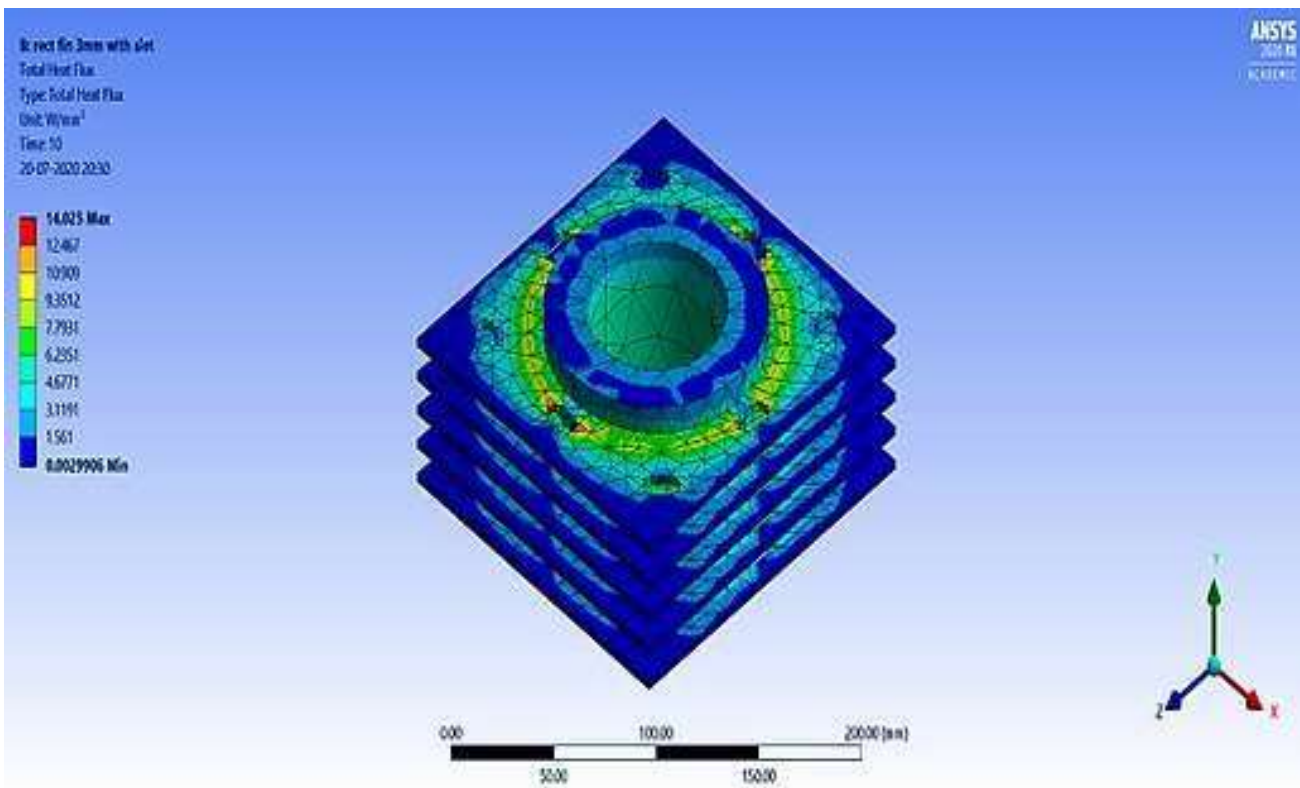
**Figure 18.** Total heat transfer per unit area in rectangular fin 2 mm without slot.



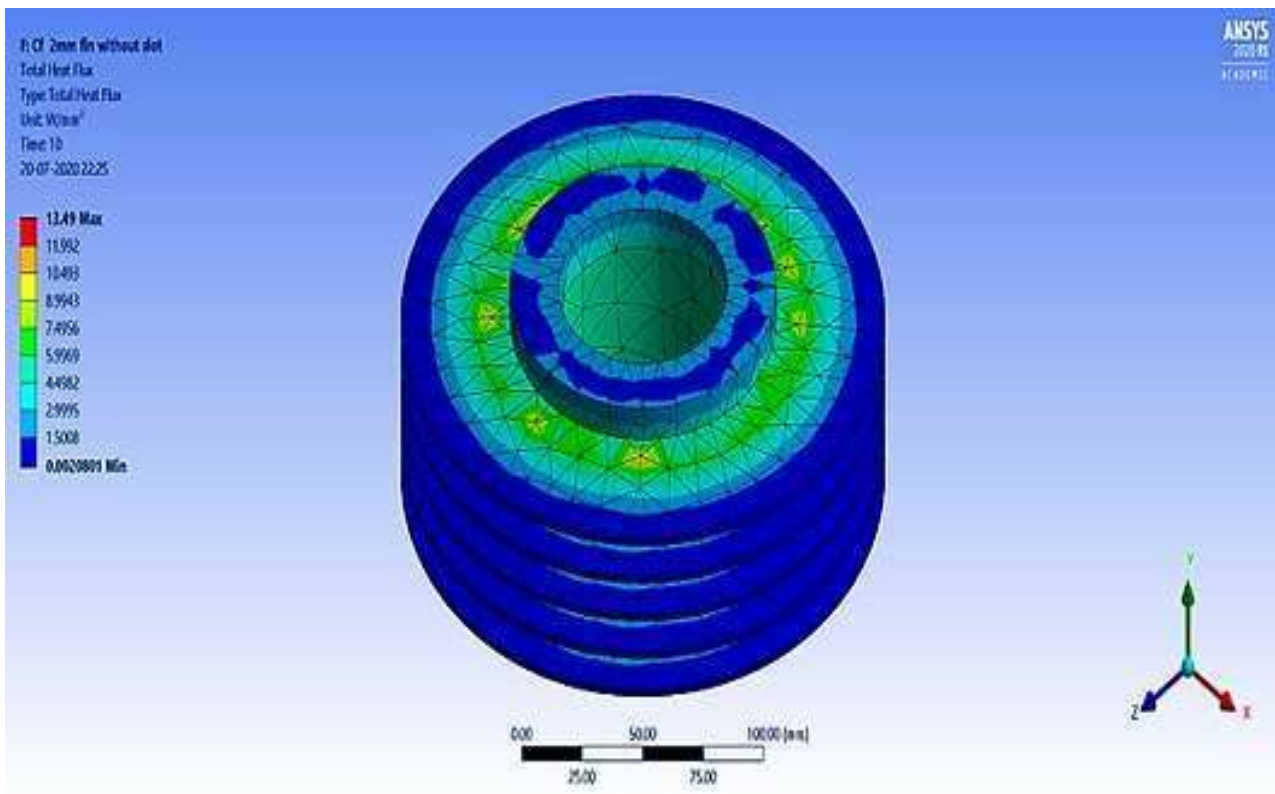
**Figure 19.** Total heat transfer per unit area in rectangular fin 2 mm with slot.



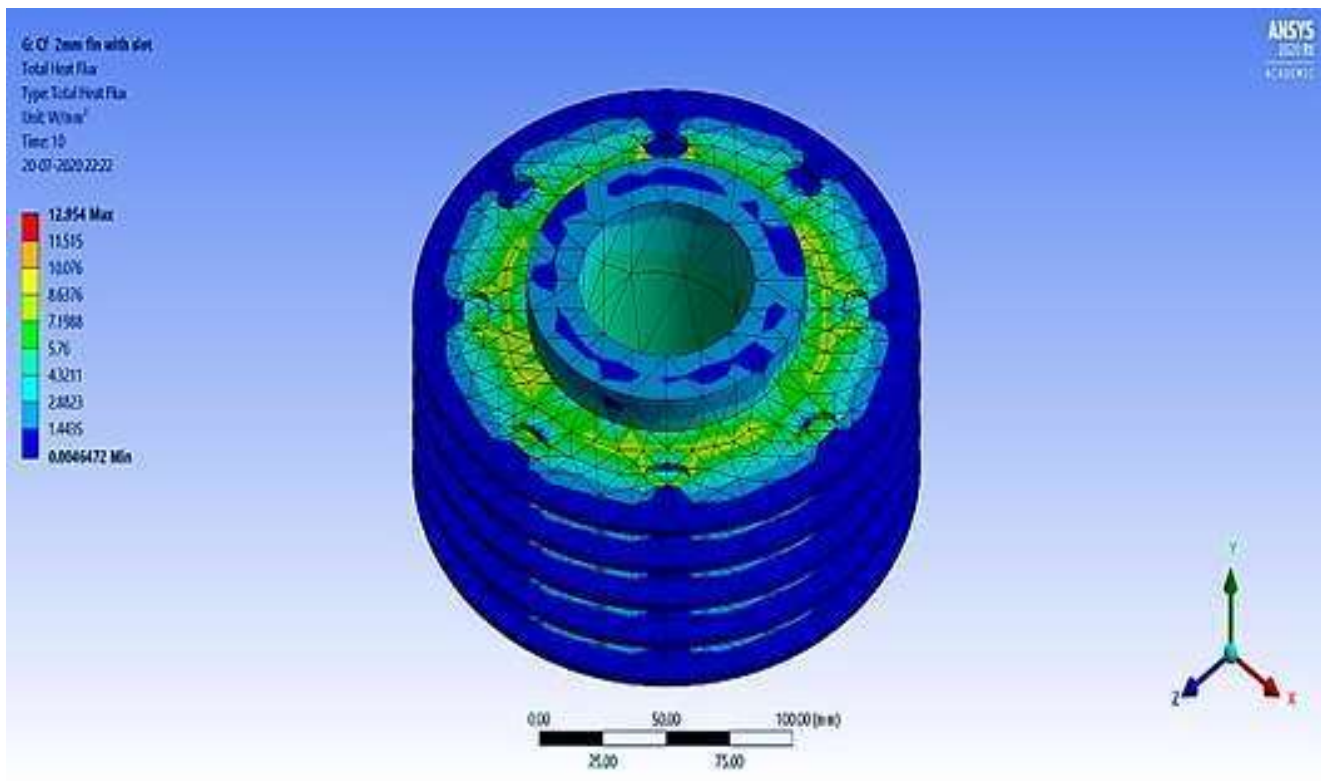
**Figure 20.** Total heat transfer per unit area in rectangular fin 3 mm without slot.



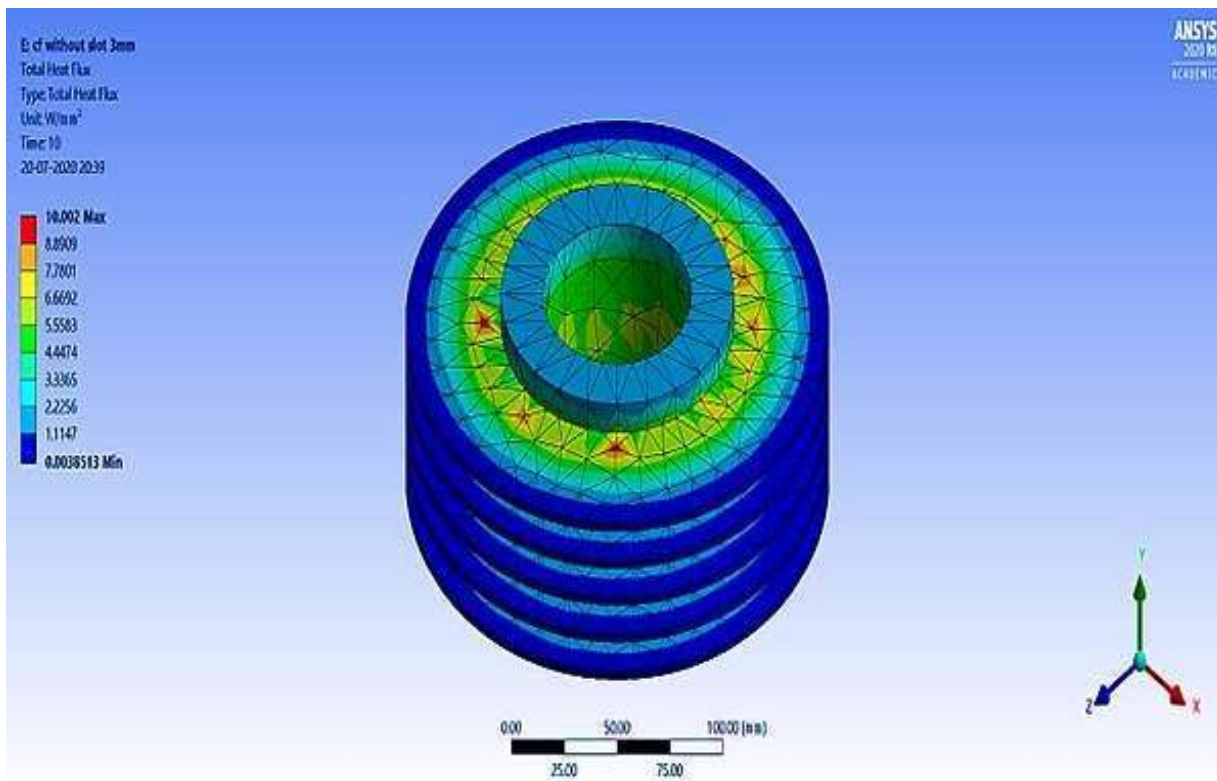
**Figure 21.** Total heat transfer per unit area in rectangular fin 3mm with slot.



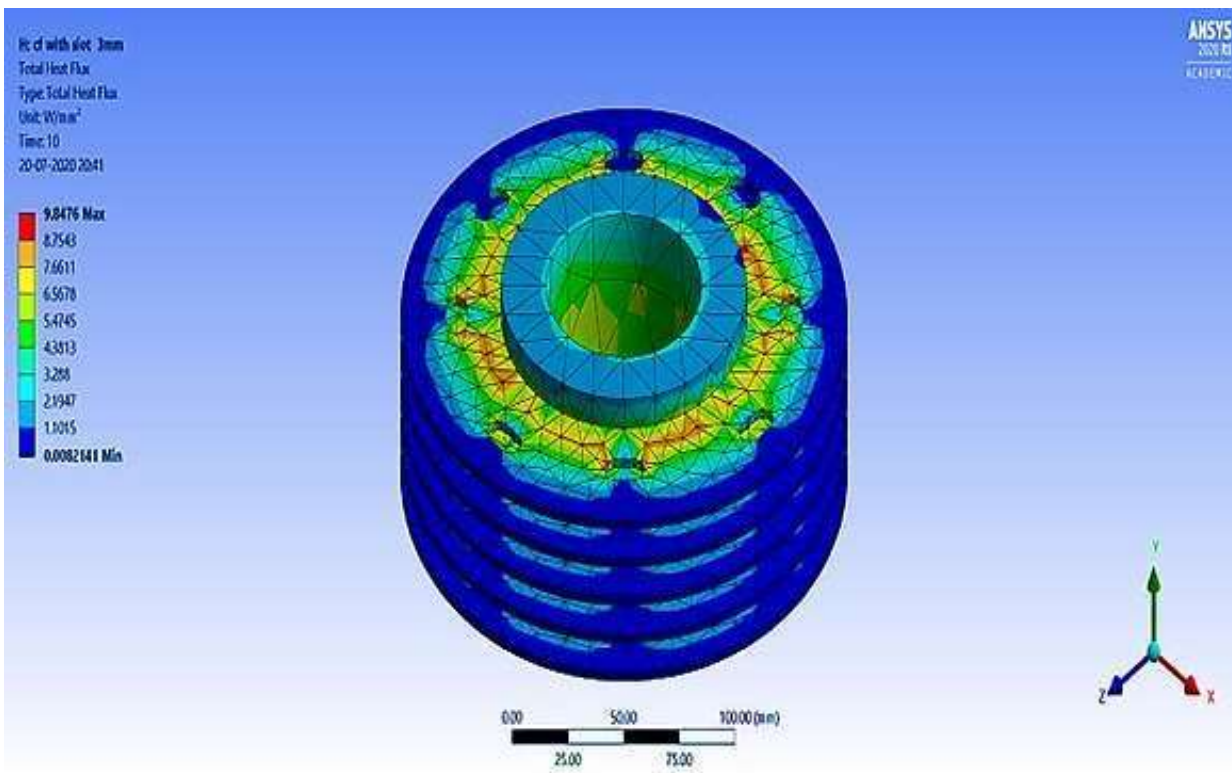
**Figure 22.** Total heat transfer per unit area in circular fin 2 mm without slot.



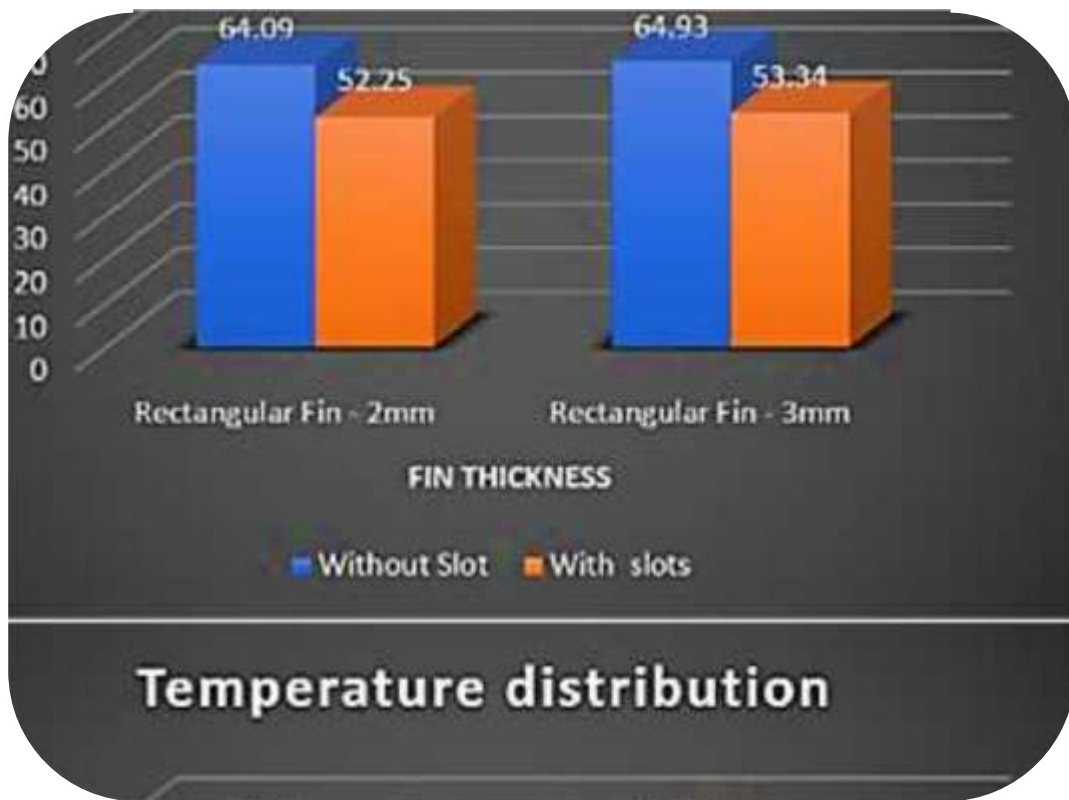
**Figure 23.** Total heat transfer per unit area in circular fin 2 mm with slot.



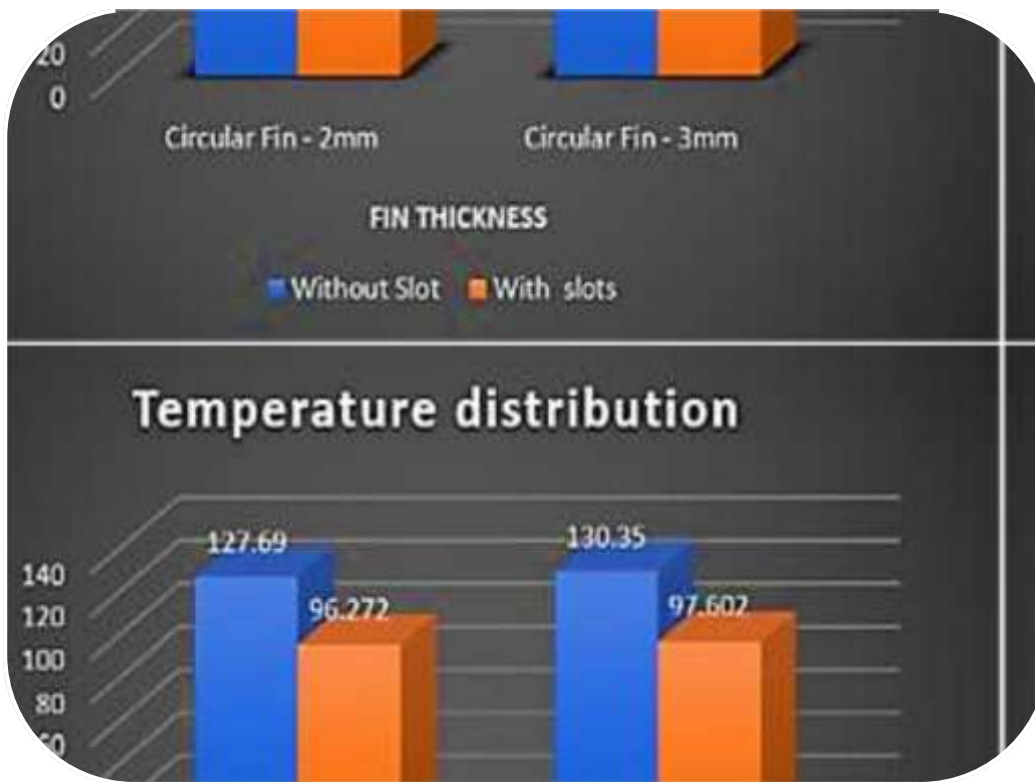
**Figure 24.** Total heat transfer per unit area in circular fin 3 mm without slot.



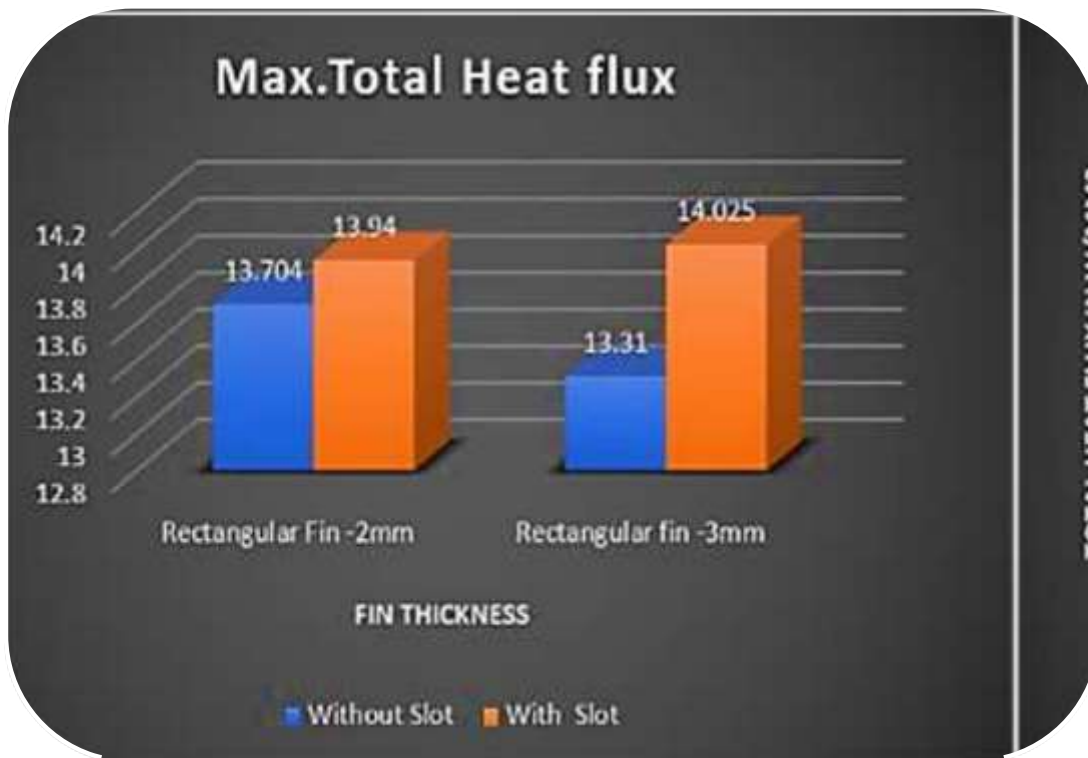
**Figure 25.** Total heat transfer per unit area in circular fin 3 mm with slot.



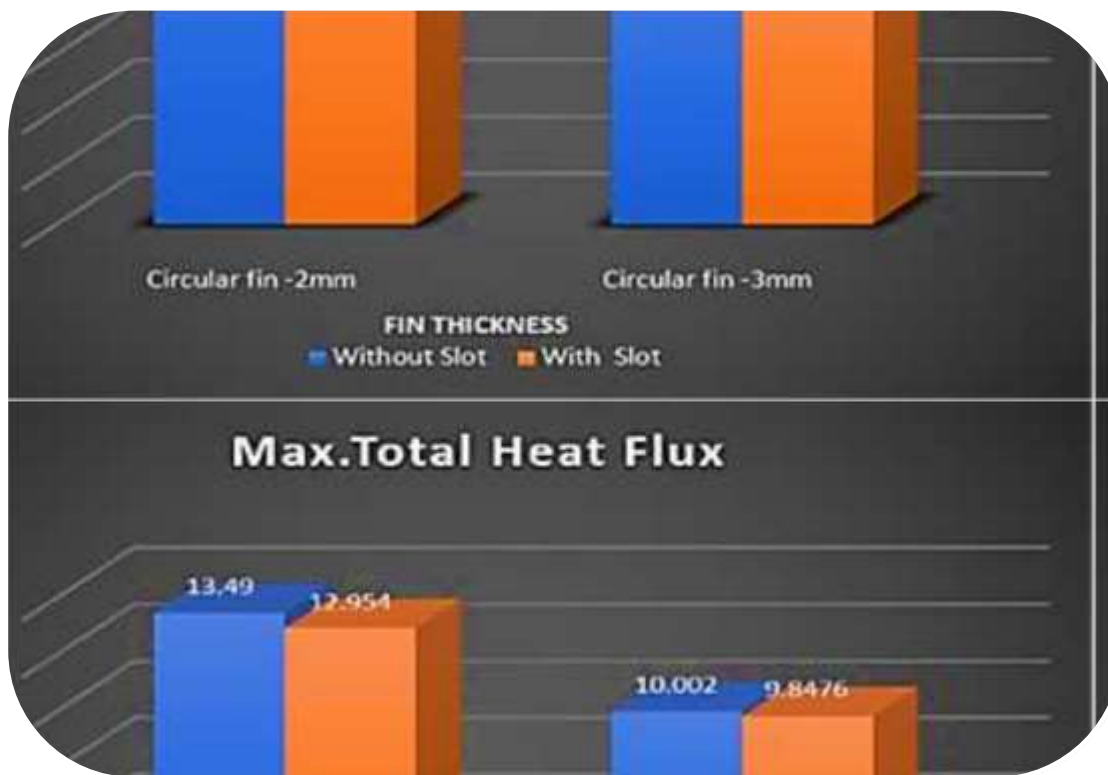
**Figure 26.** Temperature distribution in rectangular fins of varying thickness.



**Figure 27.** Temperature distribution in Circular fins of varying thickness.



**Figure 28.** Total heat transfer per unit area in rectangular fins of varying thickness.



**Figure 29.** Total heat transfer per unit area in Circular fins of varying thickness.

**Table 3.** Percentage reduction in temperature for each fin model.

Temperature	Rectangular fin (2 mm thickness)	Rectangular fin (3 mm thickness)	Circular fin (2 mm thickness)	Circular fin (3 mm thickness)
Without Slot	64.93°C	64.09°C	127.69°C	130.35°C
With Slot	53.34°C	52.25°C	96.272°C	97.602°C
% Reduction in temperature upon slot introduction	17.84%	18.47 %	24.60 %	25.12 %

**CONFLICT OF INTERESTS**

The authors have not declared any conflict of interests.

**REFERENCES**

Arvind SS, Manankumar BJ, Pravin PR (2016). Thermal Augmentation of Air Cooled 4 stroke SI Engine through Fins-A Review Paper. International Journal of Research in Engineering and Advanced Technology. 2(1):1-5.

Awasarmol UV, Pise AT (2017). Experimental Study of Heat Transfer Enhancements from Array of Alternate Rectangular Dwarf Fins at Different Inclinations. *Journal of The Institution of Engineers (India): Series C* 99(1):125-131.

Aziz A, Fang T (2010). Alternative solutions for longitudinal fins of rectangular, trapezoidal, and concave parabolic profiles, *Energy Conversion and Management* 51(11):2188-2194.

Chaitanya PS, Rani BS, Kumar KV (2014). Thermal Analysis of Engine Cylinder Fin by Varying Its Geometry and Material. *IOSR Journal of Mechanical and Civil Engineering* 11(6):37-44.

Hoang AT, Nguyen XP, Le AT, Pham MT, Hoang TH, Al-Tawaha ARMS, Yondri S (2019). Power generation characteristics of a thermoelectric modules-based power generator assisted by fishboneshaped fins: Part II–Effects of cooling water parameters. *Energy Sources, Part A: Recovery, Utilization, and Environmental Effects* pp. 1-13.

Maan A, Pitta P, Yadav J (2018). *Performance Evaluation of Rectangular Fins by Modeling and Simulations*, Springer

*Transactions in Civil and Environmental Engineering* pp. 311-318.

Mokheimer EM (2003). "Heat transfer from extended surfaces subject to variable heat transfer coefficient. *Heat and Mass Transfer*" 39(2):131138.

Patel HA, Kale VS, Joshi SU, Jadhav SD, Teli SN (2019). Comparative Thermal Analysis of Fins. In *Proceedings of International Conference on Intelligent Manufacturing and Automation*. Springer, Singapore pp. 195-204.

Rajvinder S, Suraj PS, Arshadeep S (2016). Analysis of IC engine air cooling varying geometry and material. *Imperial Journal of Interdisciplinary Research* 2(12):22454-1362.

Ravindra RN, Prashant AN (2018). Modelling and Simulation of Cylinder and Cylinder head of 4-stroke SI Engine for weight reduction. *International Journal of Engineering Science and Technology* 4 ISSN: 0975-5462, 847-853.

Sagar P, Teotia P, Sahlot AD, Thakur H (2017). Heat transfer analysis and optimization of engine fins of varying surface roughness, *Materials Today: Proceedings* 4(8):8565-8570.

Srinivasa NR, Subhash GV, Kumar KA, Malleswara Rao BN (2016). Design and study the effectiveness of engine cylinder fin with variable geometry and material. *International Journal of Research in Engineering and Technology* 5(10).

Sujan S, Nitesh KY, Suman BB (2019). Analysis of Heat transfer through fins of IC engine. Department of Mechanical Engineering, Kathmandu University, Dhulikhel, Nepal, <https://www.researchgate.net/publication/334825457>.